

Robert-James Sales, Inc.

# Orifice Flanges

Weld Neck, Slip-On, Threaded.  
ASME Class 300 - 2500

# Class 300, Welding Neck, Slip-On and Threaded ASME B16.36 Orifice Flanges

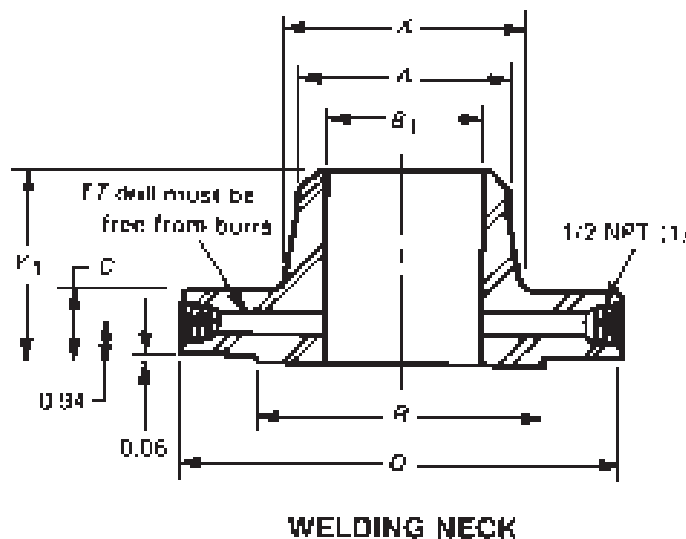

Nominal Pipe Size	Outside Dia. of Flange O	Thickness of Flange Min. C	Outside Dia. of Raised Face R	Length Thru Hub		Dia of Hub	Hub Dia. Beginning of Chamfer (W.N.) A	Dia. of Counterbore	
				Slip-On and Threaded Y <sub>2</sub>	Weld Neck Y <sub>1</sub>			Back Q <sub>a</sub>	Face Q <sub>F</sub>
1	4.88	1.50	2.00	1.88	3.25	2.12	1.32	1.41	1.30
1 1/2	6.12	1.50	2.88	1.88	3.38	2.75	1.90	1.99	1.89
2	6.50	1.50	3.62	1.94	3.38	3.31	2.38	2.50	2.36
2 1/2	7.50	1.50	4.12	2.00	3.50	3.94	2.88	3.00	2.84
3	8.25	1.50	5.00	2.06	3.50	4.62	3.50	3.63	3.46
4	10.00	1.50	6.18	2.12	3.62	5.75	4.50	4.63	4.45
6	12.50	1.50	8.50	2.13	3.94	8.12	6.63	6.75	6.57
8	15.00	1.62	10.62	2.44	4.38	10.25	8.63	8.75	8.55
10	17.50	1.88	12.75	2.62	4.62	12.62	10.75		
12	20.50	2.00	15.00	2.88	5.12	14.75	12.75		
14	23.00	2.12	16.25	3.00	5.62	16.75	14.00		
16	25.50	2.25	18.50	3.25	5.75	19.00	16.00		
18	28.00	2.38	21.00	3.50	6.25	21.00	18.00	See Note (8).	
20	30.50	2.50	23.00	3.75	6.38	23.12	20.00		
24	36.00	2.75	27.25	4.19	6.62	27.62	24.00		

GENERAL NOTE: Dimensions are in inches.

**NOTES:**

- (1) Other NPT sizes may be furnished if required.
- (2) For slip-on and threaded flanges, verify that *TT* drilling extends to inside diameter of pipe after assembly and is free from burrs.
- (3) Weld neck flanges NPS 3 and smaller are identical to Class 600 flanges and may be so marked.
- (4) All other dimensions are in accordance with ASME B16.5.

# Class 300, Welding Neck, Slip-On and Threaded ASME B16.36 Orifice Flanges

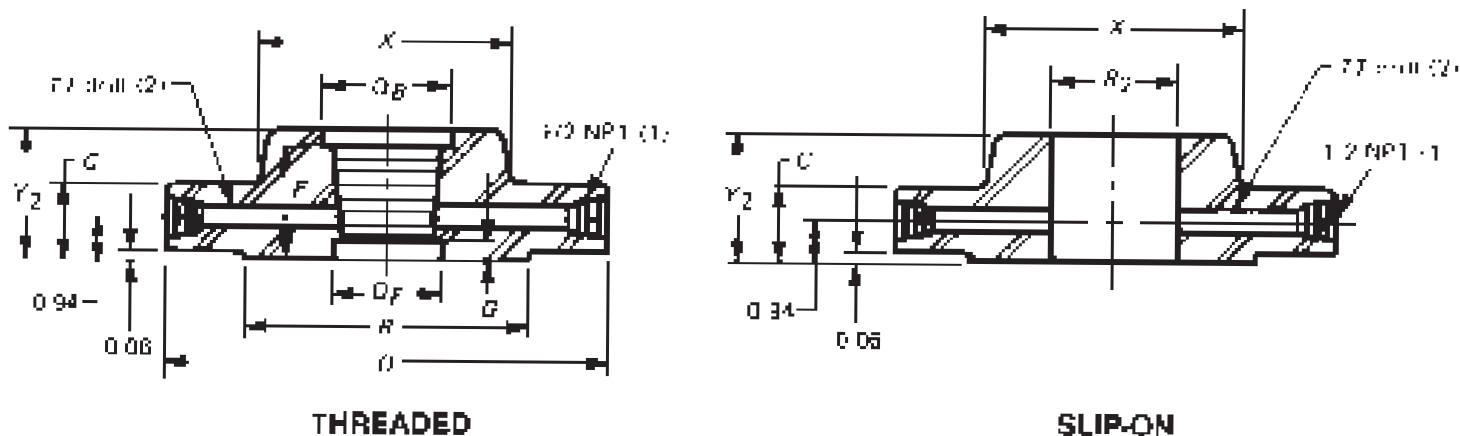

Counterbore Depth (From Face)		Bore		Dia. of Pressure Connection TT	Drilling Template				
F	G	Slip-On B <sub>2</sub>	Weld Neck B <sub>1</sub>		Bolt Circle	No. of Holes	Dia. of Holes	Stud Bolt Size	Jack Screw Size (2)
1.44	0.75	1.36	See Note (7).	1/4	3.50	4	0.69	.63 x 5.00	.63 x 4.50
1.47	0.72	1.95		1/4	4.50	4	0.81	.75 x 5.25	.63 x 4.50
1.50	0.69	2.44		1/4	5.00	8	0.69	.63 x 5.00	.63 x 4.50
1.75	0.56	2.94		1/4	5.88	8	0.81	.75 x 5.25	.63 x 4.50
1.81	0.56	3.57		3/8	6.62	8	0.81	.75 x 5.25	.63 x 4.50
1.88	0.56	4.57		1/2	7.88	8	0.81	.75 x 5.25	.75 x 4.50
1.88	0.31	6.72		1/2	10.62	12	0.80	.75 x 5.25	.75 x 4.50
2.19	0.44	8.72		1/2	13.00	12	1.00	.88 x 5.75	.75 x 4.50
		10.88		1/2	15.25	16	1.12	1.00 x 6.50	.75 x 4.50
		12.88		1/2	17.75	16	1.25	1.13 x 7.00	1.00 x 4.50
		14.14		1/2	20.25	20	1.25	1.13 x 7.25	1.00 x 4.50
		16.16		1/2	22.50	20	1.38	1.25 x 7.75	1.00 x 5.00
See Note (8).		18.18		1/2	24.75	24	1.38	1.25 x 8.00	1.00 x 5.00
		20.20		1/2	27.00	24	1.38	1.25 x 8.50	1.00 x 5.00
		24.25	1/2	32.00	24	1.62	1.50 x 9.50	1.00 x 5.00	

- (5) Bolt lengths include allowance for orifice and gasket thickness of 0.25 in. for NPS 1-12 and 0.38 in. for NPS 14-24.  
 (6) In conformance with ASME B16.5, stud bolt lengths do not include point heights.  
 (7) Bore diameter of weld neck flanges is to be specified by the purchaser.  
 (8) Threaded flanges are furnished in NPS 1-8 only.

# Class 400, Welding Neck<sup>2</sup>

## ASME B16.36 Orifice Flanges

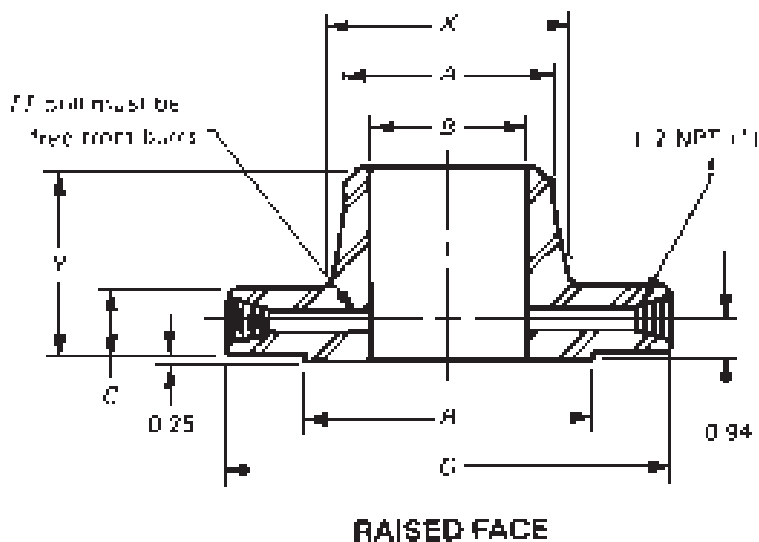

Nominal Pipe Size	Outside Dia. of Flange O	Thickness of Flange Min. C	Outside Dia. of Raised Face R	Length Thru Hub Y	Ring Type Joint					
					Groove Number	Pitch Dia. P	Groove Depth E	Groove Width F	Radius at Bottom $r_{max}$	Special Oval Ring Height W
1										
1 1/2										
2	For NPS 3 and smaller, use Class 600.									
2 1/2										
3										
4	10.00	1.50	6.19	3.50	R37	5.875	0.312	0.469	0.03	1.06
6	12.50	1.62	8.50	4.06	R45	8.312	0.312	0.469	0.03	1.06
8	15.00	1.88	10.62	4.62	R49	10.625	0.312	0.469	0.03	1.06
10	17.50	2.12	12.75	4.88	R53	12.750	0.312	0.469	0.03	1.06
12	20.50	2.25	15.00	5.38	R57	15.000	0.312	0.469	0.03	1.06
14	23.00	2.39	16.25	5.88	R61	16.500	0.312	0.469	0.03	1.06
16	25.50	2.50	18.50	6.00	R65	18.500	0.312	0.469	0.03	1.19
18	28.00	2.62	21.00	6.50	R69	21.000	0.312	0.469	0.03	1.19
20	30.50	2.75	23.00	6.62	R73	23.000	0.375	0.531	0.06	1.25
24	36.00	3.00	27.25	6.88						See Note (6).

GENERAL NOTE: Dimensions are in inches.

**NOTES:**

- (1) Other NPT sizes may be furnished if required.
- (2) All other dimensions are in accordance with ASME B16.5.
- (3) In conformance with ASME B16.5, stud bolt lengths do not include point heights

# Class 400, Welding Neck<sup>2</sup>

## ASME B16.36 Orifice Flanges

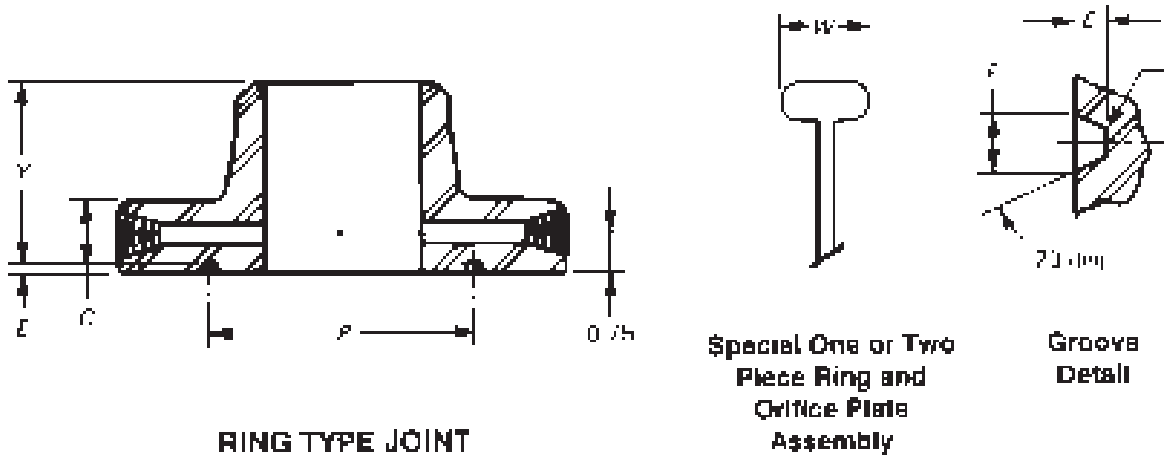

Dia. of Hub X	Hub Dia. Beginning of Chamfer A	Bore B	Dia. of Pressure Connection TT	Drilling Template				Length of Stud Bolts [(3), (4)]	
				Dia. of Bolt Circle	No. of Holes	Dia. of Holes	Dia. of Bolts	Raised Face	Ring Joint
For NPS 3 and smaller, use Class 600.									
5.75	4.50	See Note (5).	1/2	7.88	8	1.00	7/8	5.50	6.00
8.12	6.63		1/2	10.62	12	1.00	7/8	6.25	6.50
10.25	8.63		1/2	13.00	12	1.12	1	6.75	7.25
12.62	10.75		1/2	15.25	16	1.25	1 1/8	7.50	8.00
14.75	12.75		1/2	17.75	16	1.38	1 1/4	8.00	8.50
16.75	14.00		1/2	20.25	20	1.38	1 1/4	8.25	9.00
19.00	16.00		1/2	22.50	20	1.50	1 3/8	8.75	9.25
21.00	18.00		1/2	24.75	24	1.50	1 3/8	9.25	9.50
23.12	20.00		1/2	27.00	24	1.62	1 1/2	9.75	10.25
27.62	24.00		1/2	32.00	24	1.88	1 3/4	10.00	—

(4) Bolt lengths for raised face flanges include allowance for orifice and gasket thickness of 0.25 in. for NPS 4-12 and 0.38 in. for NPS 14-24. Bolt lengths for ring type joint flanges include allowance of 0.62 in. for NPS 4-10, 0.75 in. for NPS 12-18, and 0.88 in. for NPS 20.

(5) Bore is to be specified by purchaser.

(6) Ring joint flange is not shown in NPS 24 due to insufficient metal between groove and pressure tap hole.

(7) All Texas Metal Works RTJ orifice flanges are 0.94 pressure tap center.

# Class 600, Welding Neck<sup>2, 3</sup>

## ASME B16.36 Orifice Flanges

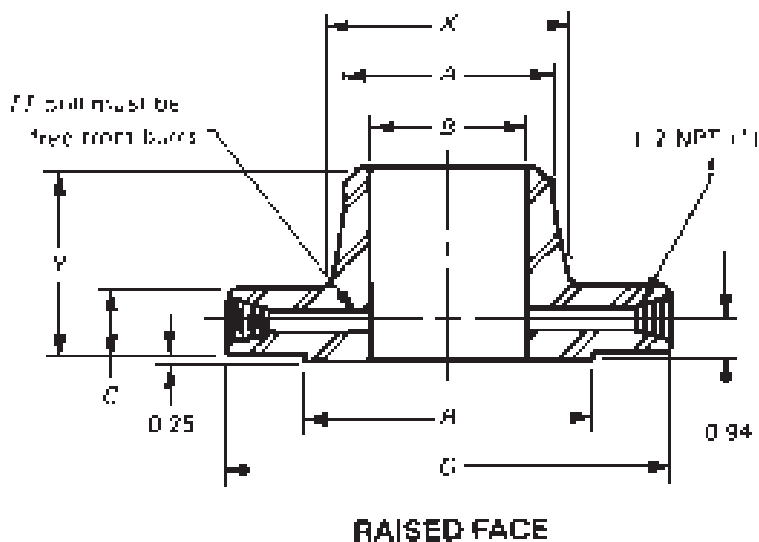

Nominal Pipe Size	Outside Dia. of Flange O	Thickness of Flange (4) Min. C	Outside Dia. of Raised Face R	Length Thru Hub (4) Y	Height of Raised Face H	Ring Type Joint					
						Groove Number	Pitch Dia. P	Groove Depth E	Groove Width F	Radius at Bottom $r_{max}$	Special Oval Ring Height W
1	4.88	1.50	2.00	3.25	0.06	R16	2.000	0.250	0.344	0.03	1.00
1 1/2	6.12	1.50	2.88	3.38	0.06	R20	2.688	0.250	0.344	0.03	1.00
2	6.50	1.50	3.62	3.38	0.06	R23	3.250	0.312	0.469	0.03	1.06
2 1/2	7.50	1.50	4.12	3.50	0.06	R26	4.000	0.312	0.469	0.03	1.06
3	8.25	1.50	5.00	3.50	0.06	R31	4.875	0.312	0.469	0.03	1.06
4	10.75	1.50	6.19	4.00	0.25	R37	5.875	0.312	0.469	0.03	1.06
6	14.00	1.88	8.50	4.62	0.25	R45	8.312	0.312	0.469	0.03	1.06
8	16.50	2.19	10.62	5.25	0.25	R49	10.625	0.312	0.469	0.03	1.06
10	20.00	2.50	12.75	6.00	0.25	R53	12.750	0.312	0.469	0.03	1.06
12	22.00	2.62	15.00	6.12	0.25	R57	15.000	0.312	0.469	0.03	1.06
14	23.75	2.75	16.25	6.50	0.25	R61	16.500	0.312	0.469	0.03	1.06
16	27.00	3.00	18.00	7.00	0.25	R65	18.500	0.312	0.469	0.03	1.19
18	29.25	3.25	21.00	7.25	0.25	R69	21.000	0.312	0.469	0.03	1.19
20	32.00	3.50	23.00	7.50	0.25	R73	23.000	0.375	0.531	0.06	1.25
24	37.00	4.00	27.25	8.00	0.25	See Note (8).					

GENERAL NOTE: Dimensions are in inches.

NOTES:

- (1) Other NPT sizes may be furnished if required.
- (2) Weldneck flanges NPS 3 and smaller are identical to Class 300 flanges except for bolting and may be used for such service.
- (3) All other dimensions are in accordance with ASME B16.5.
- (4) 0.06 in. height of raised face in NPS 1-3 is included in dimensions C and Y.

# Class 600, Welding Neck<sup>2, 3</sup>

## ASME B16.36 Orifice Flanges

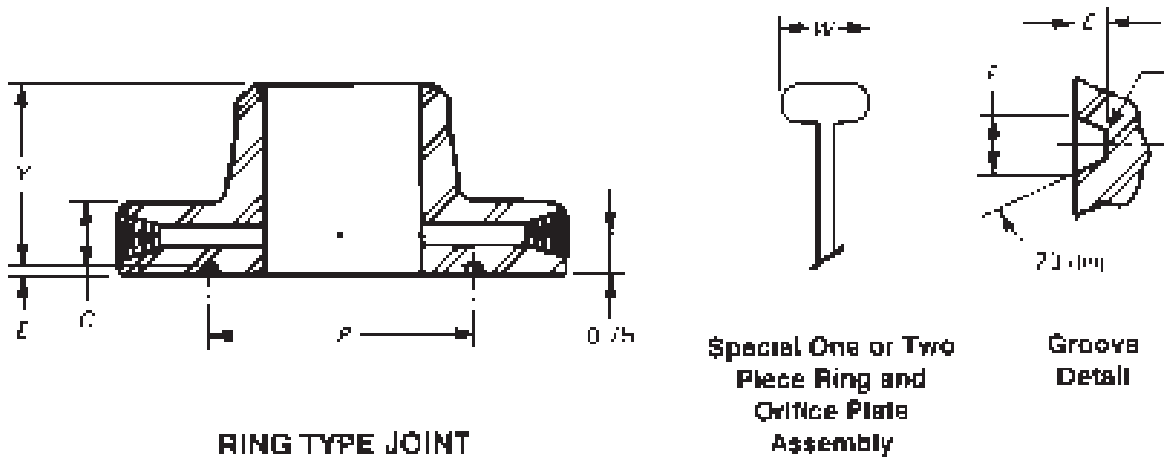

Dia. of Hub X	Hub Dia. Beginning of Chamfer A	Bore B	Dia. of Pressure Connection TT	Drilling Template					Length of Stud Bolts [(3), (4)]		Nominal Pipe Size
				Dia. of Bolt Circle	No. of Holes	Dia. of Holes		Dia. of Bolts	Raised Face	Ring Joint	
						Raised Face	Ring Joint				
2.12	1.32		1/4	3.50	4	0.69	0.75	5/8	5.00	5.50	1
2.75	1.90		1/4	4.50	4	0.88	0.88	3/4	5.25	5.50	1 1/2
3.31	2.38		1/4	5.00	8	0.75	0.75	5/8	5.00	5.50	2
3.94	2.88		1/4	5.88	8	0.88	0.88	3/4	5.25	5.75	2 1/2
4.62	3.50	See Note (5).	3/8	6.62	8	0.88	0.88	3/4	5.25	5.75	3
6.00	4.50		1/2	8.50	8	1.00	1.00	7/8	6.00	6.50	4
8.75	6.63		1/2	11.50	12	1.12	1.12	1	7.00	7.50	6
10.75	8.63		1/2	13.75	12	1.25	1.25	1 1/8	7.75	8.25	8
13.50	10.75		1/2	17.00	16	1.38	1.38	1 1/4	8.75	9.25	10
15.75	12.75		1/2	19.25	20	1.38	1.38	1 1/4	9.00	9.50	12
17.00	14.00		1/2	20.75	20	1.50	1.50	1 3/8	9.50	10.00	14
19.50	16.00		1/2	23.75	20	1.62	1.62	1 1/2	10.75	10.75	16
21.50	18.00		1/2	25.75	20	1.75	1.75	1 5/8	11.00	11.50	18
24.00	20.00		1/2	28.50	24	1.75	1.75	1 5/8	11.75	12.50	20
28.25	24.00	1/2	33.00	24	2.00	2.00	1 7/8	13.25	—	24	

- (5) Bolt lengths for raised face flanges include allowance for orifice and gasket thickness of 0.25 in. for NPS 1-12 and 0.38 in. for NPS 14-24. Bolt lengths for ring type joint flanges include allowance of 0.62 in. for NPS 1-10, 0.75 in. for NPS 12-18, and 0.88 in. for NPS 20.
- (6) In conformance with ASME B16.5, stud bolt lengths do not include point heights.
- (7) Bore is to be specified by purchaser.
- (8) Ring joint flange is not shown in NPS 24 due to insufficient metal between groove and pressure tap hole.
- (9) All Texas Metal Works RTJ orifice flanges are 0.94 pressure tap center.

# Class 900, Welding Neck<sup>2</sup>

## ASME B16.36 Orifice Flanges

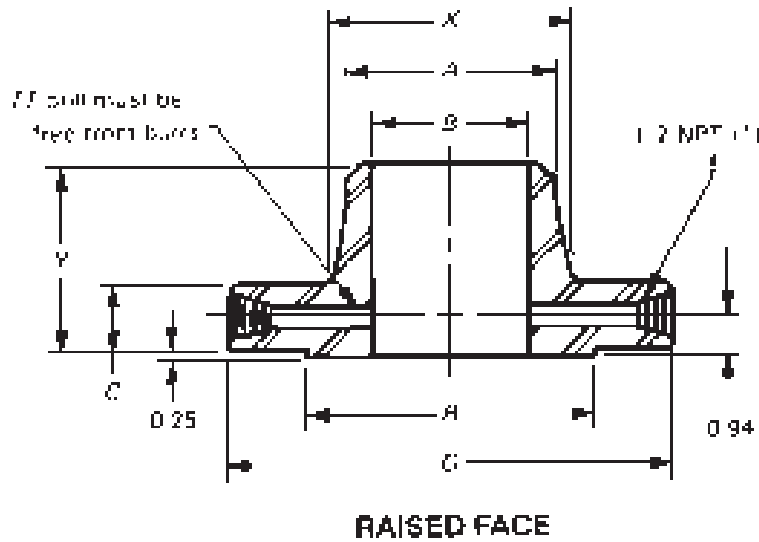

Nominal Pipe Size	Outside Dia. of Flange O	Thickness of Flange Min. C	Outside Dia. of Raised Face R	Length Thru Hub Y	Ring Type Joint					
					Groove Number	Pitch Dia. P	Groove Depth E	Groove Width F	Radius at Bottom $r_{max}$	Special Oval Ring Height W
1										
1 1/2										
2	For NPS 2 1/2 and smaller, use Class 1500.									
2 1/2										
3	9.50	1.50	5.00	4.00	R31	4.875	0.312	0.469	0.03	1.06
4	11.50	1.75	6.19	4.50	R37	5.875	0.312	0.469	0.03	1.06
6	15.00	2.19	8.50	5.50	R45	8.312	0.312	0.469	0.03	1.06
8	18.50	2.50	10.62	6.38	R49	10.625	0.312	0.469	0.03	1.06
10	21.50	2.75	12.75	7.25	R53	12.750	0.312	0.469	0.03	1.06
12	24.00	3.12	15.00	7.88	R57	15.000	0.312	0.469	0.03	1.06
14	25.25	3.38	16.25	8.38						
16	27.75	3.50	18.50	8.50						
18	31.00	4.00	21.00	9.00						
20	33.75	4.25	23.00	9.75						
24	41.00	5.50	27.25	11.50						

GENERAL NOTE: Dimensions are in inches.

**NOTES:**

- (1) Other NPT sizes may be furnished if required.
- (2) All other dimensions are in accordance with ASME B16.5.
- (3) In conformance with ASME B16.5, stud bolt lengths do not include point heights



# Class 900, Welding Neck<sup>2</sup>

## ASME B16.36 Orifice Flanges

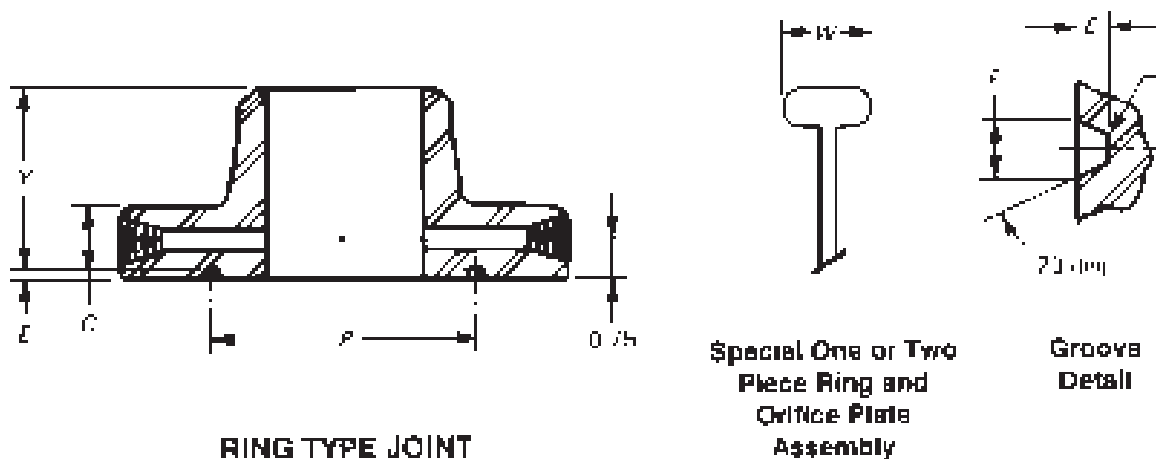

Dia. of Hub X	Hub Dia. Beginning of Chamfer A	Bore B	Dia. of Pressure Connection TT	Drilling Template				Length of Stud Bolts [(3), (4)]	
				Dia. of Bolt Circle	No. of Holes	Dia. of Holes	Dia. of Bolts	Raised Face	Ring Joint
For NPS 2 1/2 and smaller, use Class 1500.									
5.00	3.50	See Note (5).	3/8	7.50	8	1.00	7/8	6.00	6.50
6.25	4.50		1/2	9.25	8	1.25	1 1/8	7.00	7.50
9.25	6.63		1/2	12.50	12	1.25	1 1/8	7.75	8.25
11.75	8.63		1/2	15.50	12	1.50	1 3/8	9.00	9.50
14.50	10.75		1/2	18.50	16	1.50	1 3/8	9.50	10.00
16.50	12.75		1/2	21.00	16	1.50	1 3/8	10.25	10.75
17.75	14.00		1/2	22.00	20	1.62	1 1/2	11.00	—
20.00	16.00		1/2	24.25	20	1.75	1 5/8	11.50	—
22.25	18.00		1/2	27.00	20	2.00	1 7/8	13.00	—
24.50	20.00		1/2	29.50	20	2.12	2	14.00	—
29.50	24.00	1/2	35.50	20	2.62	2 1/2	12.50	—	

- (4) Bolt lengths for raised face flanges include allowance for orifice and gasket thickness of 0.25 in. for NPS 3-12 and 0.38 in. for NPS 14-24. Bolt lengths for ring type joint flanges include allowance of 0.62 in. for NPS 3-10 and 0.75 in. for NPS 12.
- (5) Bore is to be specified by purchaser.
- (6) Ring joint flanges larger than NPS 12 are not shown due to insufficient metal between groove and pressure tap hole.
- (7) All Texas Metal Works RTJ orifice flanges are 0.94 pressure tap center.

# Class 1500, Welding Neck<sup>2</sup>

## ASME B16.36 Orifice Flanges

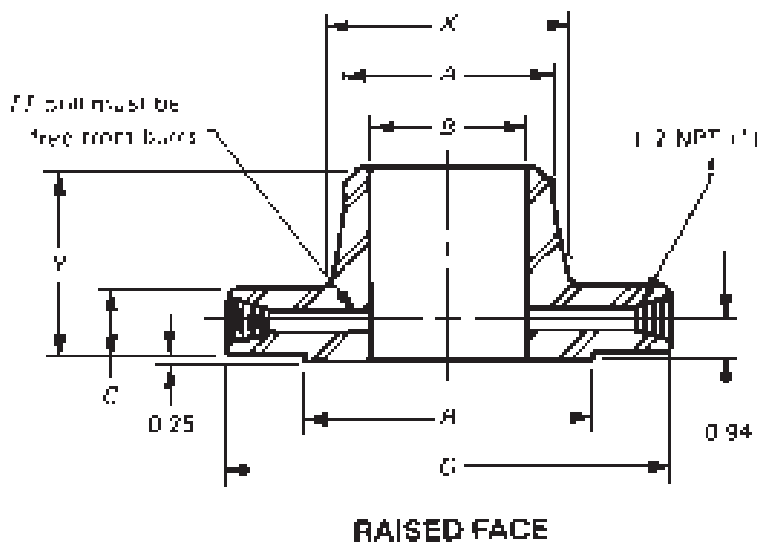

Nominal Pipe Size	Outside Dia. of Flange O	Thickness of Flange Min. C	Outside Dia. of Raised Face R	Length Thru Hub Y	Ring Type Joint					
					Groove Number	Pitch Dia. P	Groove Depth E	Groove Width F	Radius at Bottom $r_{max}$	Special Oval Ring Height W
1	5.88	1.50	2.00	3.25	R16	2.000	0.250	0.344	0.03	1.00
1 1/2	7.00	1.50	2.88	3.50	R20	2.688	0.250	0.344	0.03	1.00
2	8.50	1.50	3.62	4.00	R24	3.750	0.312	0.469	0.03	1.06
2 1/2	9.62	1.62	4.12	4.12	R27	4.250	0.312	0.469	0.03	1.06
3	10.50	1.88	5.00	4.62	R35	5.375	0.312	0.469	0.03	1.06
4	12.25	2.12	6.19	4.88	R39	6.375	0.312	0.469	0.03	1.06
6	15.50	3.25	8.50	6.75	R46	8.312	0.375	0.531	0.06	1.12
8	19.00	3.62	10.62	8.38						
10	23.00	4.25	12.75	10.00						
12	26.50	4.88	15.00	11.12						
14	29.50	5.25	16.25	11.75						
16	32.50	5.75	18.50	12.25						
18	36.00	6.38	21.00	12.88						
20	38.75	7.00	23.00	14.00						
24	46.00	8.00	27.25	16.00						

GENERAL NOTE: Dimensions are in inches.

NOTES:

- (1) Other NPT sizes may be furnished if required.
- (2) All other dimensions are in accordance with ASME B16.5.
- (3) In conformance with ASME B16.5, stud bolt lengths do not include point heights

# Class 1500, Welding Neck<sup>2</sup>

## ASME B16.36 Orifice Flanges

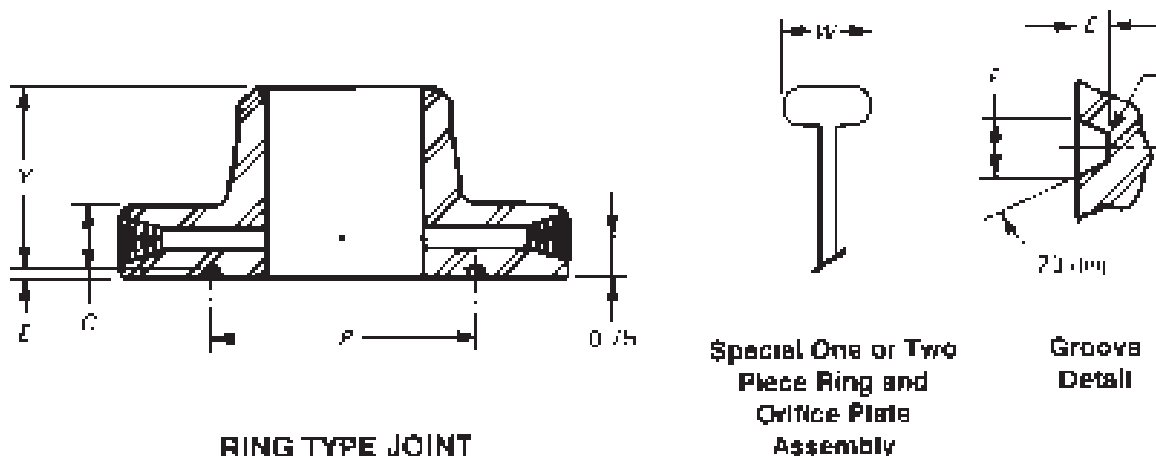

**RING TYPE JOINT**

**Special One or Two Piece Ring and Orifice Plate Assembly**

**Groove Detail**

Dia. of Hub X	Hub Dia. Beginning of Chamfer A	Bore B	Dia. of Pressure Connection TT	Drilling Template				Length of Stud Bolts [(3), (4)]	
				Dia. of Bolt Circle	No. of Holes	Dia. of Holes	Dia. of Bolts	Raised Face	Ring Joint
2.06	1.32		1/4	4.00	4	1.00	7/8	6.00	6.25
2.75	1.90		1/4	4.88	4	1.12	1	6.25	6.50
4.12	2.38		1/4	6.50	8	1.00	7/8	6.00	6.50
4.88	2.88		1/4	7.50	8	1.12	1	6.50	7.00
5.25	3.50	See Note (5).	3/8	8.00	8	1.25	1 1/8	7.25	7.25
6.38	4.50		1/2	9.50	8	1.38	1 1/4	8.00	8.50
9.00	6.63		1/2	12.50	12	1.50	1 3/8	10.50	11.00
11.50	8.63		1/2	15.50	12	1.75	1 5/8	11.75	—
14.50	10.75		1/2	19.00	12	2.00	1 7/8	13.50	—
17.75	12.75		1/2	22.50	16	2.12	2	15.00	—
19.50	14.00		1/2	25.00	16	2.38	2 1/4	16.25	—
21.75	16.00		1/2	27.75	16	2.62	2 1/2	17.75	—
23.50	18.00		1/2	30.50	16	2.88	2 3/4	19.75	—
25.25	20.00		1/2	32.75	16	3.12	3	21.50	—
30.00	24.00	1/2	39.00	16	3.62	3 1/2	24.50	—	

(4) Bolt lengths for raised face flanges include allowance for orifice and gasket thickness of 0.25 in. for NPS 1-12 and 0.38 in. for NPS 14-24. Bolt lengths for ring type joint flanges include allowance of 0.62 in. for NPS 1-6.

(5) Bore is to be specified by purchaser.

(6) Ring joint flanges larger than NPS 6 are not shown due to insufficient metal between groove and pressure tap hole.

(7) All Texas Metal Works RTJ orifice flanges are 0.94 pressure tap center.

# Class 2500, Welding Neck<sup>2</sup>

## ASME B16.36 Orifice Flanges

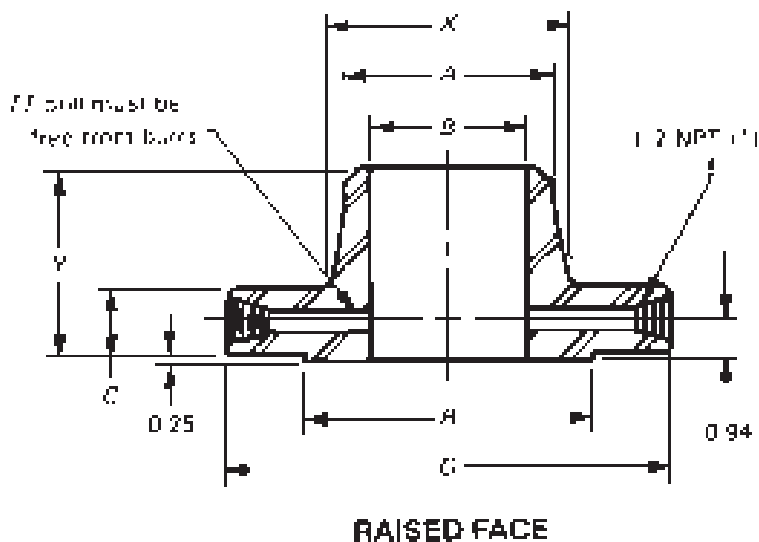

Nominal Pipe Size	Outside Dia. of Flange O	Thickness of Flange Min. C	Outside Dia. of Raised Face R	Length Thru Hub Y	Ring Type Joint					
					Groove Number	Pitch Dia. P	Groove Depth E	Groove Width F	Radius at Bottom $r_{max}$	Special Oval Ring Height W
1	6.25	1.50	2.00	3.62	R18	2.375	0.250	0.344	0.03	1.00
1 1/2	8.00	1.75	2.88	4.38	R23	3.250	0.312	0.469	0.03	1.06
2	9.25	2.00	3.62	5.00	R26	4.000	0.312	0.469	0.03	1.06
2 1/2	10.50	2.25	4.12	5.62	R28	4.375	0.375	0.531	0.06	1.19
3	12.00	2.62	5.00	6.62	R32	5.000	0.375	0.531	0.06	1.19
4	14.00	3.00	6.19	7.50						
6	19.00	4.25	8.50	10.75						
8	21.75	5.00	10.62	12.50						
10	26.50	6.50	12.75	16.50						
12	30.00	7.25	15.00	18.25						

GENERAL NOTE: Dimensions are in inches.

NOTES:

- (1) Other NPT sizes may be furnished if required.
- (2) All other dimensions are in accordance with ASME B16.5.
- (3) In conformance with ASME B16.5, stud bolt lengths do not include point heights

# Class 2500, Welding Neck<sup>2</sup>

## ASME B16.36 Orifice Flanges

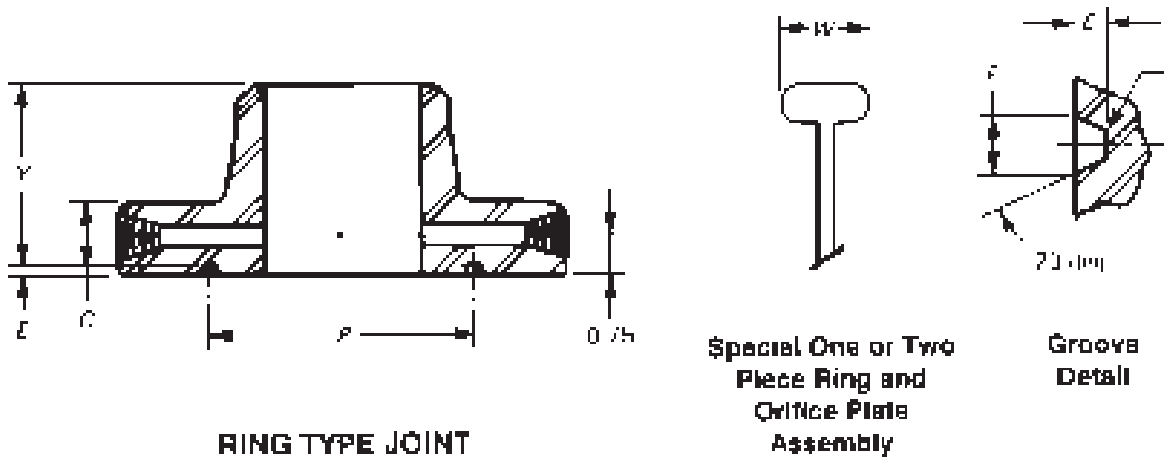

Dia. of Hub X	Hub Dia. Beginning of Chamfer A	Bore B	Dia. of Pressure Connection TT	Drilling Template				Length of Stud Bolts [(3), (4)]	
				Dia. of Bolt Circle	No. of Holes	Dia. of Holes	Dia. of Bolts	Raised Face	Ring Joint
2.25	1.32	See Note (5).	1/4	4.25	4	1.00	7/8	6.00	6.25
3.12	1.90		1/4	5.75	4	1.25	1 1/8	7.00	7.50
3.75	2.38		1/4	6.75	8	1.12	1	7.25	7.75
4.50	2.88		1/4	7.75	8	1.25	1 1/8	8.00	8.50
5.25	3.50		3/8	9.00	8	1.38	1 1/4	9.00	9.50
6.50	4.50		1/2	10.75	8	1.62	1 1/2	10.25	10.75
9.25	6.63		1/2	14.50	8	2.12	2	13.75	14.50
12.00	8.63		1/2	17.25	12	2.12	2	15.75	16.00
14.75	10.75		1/2	21.25	12	2.62	2 1/2	19.25	20.25
17.35	12.75		1/2	24.38	12	2.88	2 3/4	21.25	22.50

- (4) Bolt lengths for raised face flanges include allowance for orifice and gasket thickness of 0.25 in. for NPS 1-12. Bolt lengths for ring type joint flanges include allowance of 0.62 in. for NPS 1-3.
- (5) Bore is to be specified by purchaser.
- (6) Ring joint flanges larger than NPS 3 are not shown due to insufficient metal between groove and pressure tap hole.
- (7) All Texas Metal Works RTJ orifice flanges are 0.94 pressure tap center.